

Decision-Making Tool

Option	Describe	Total Points
A	Continue checking up on people online	-30
B	Stop checking up on people entirely	+70

Advantages of Option A

- Fun/exciting
- In control/upper hand
- Motivates me/creates desire
- I know lots of info other's don't
- Fun to share findings
- Feel like a private detective
- Might find new information about husband's past

Disadvantages of Option A

- Feel mad, upset, jealous a lot
- Waste a lot of time
- Feel like a sneak/bad person
- Feel obsessed & like I can't stop
- Husband could find out & think badly of me

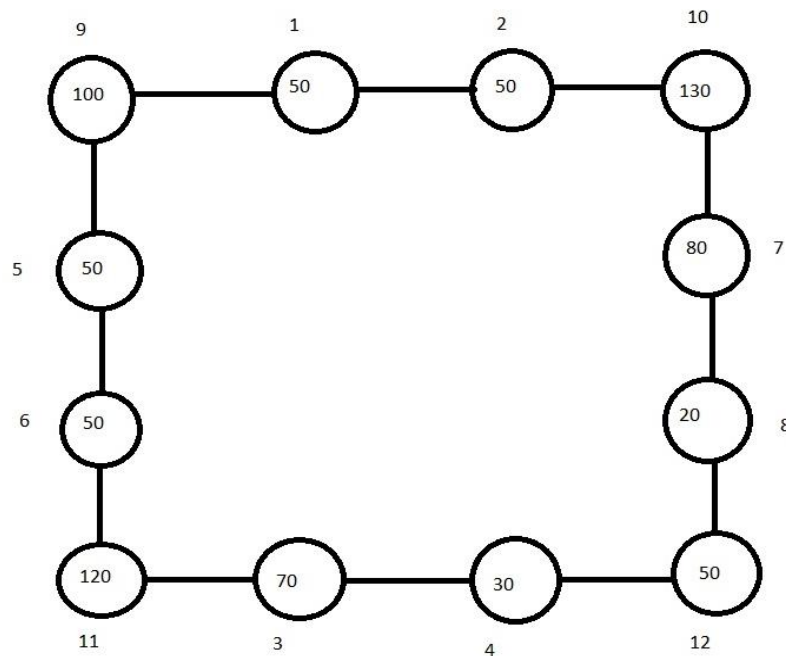

Advantages of Option B

- Feel free
- Only worry about myself from now on
- Less stress & anger
- More time spent productively
- Less time spent online
- Enjoy what I have more
- No more guilt!

Disadvantages of Option B

- Not finding out what's going on
- Bored/too much down time
- Nothing to compare myself to
- Miss out on info about husband's past